

MIS-3500 series Integrated Pressure Sensor

■ Features

- Factory calibrated and temperature compensated.
- $\pm 1.3\%$ FS accuracy (20 to 60°C)
- 3V or 5V rail to rail ratiometric analog output
- Gauge pressure or vacuum type.
- Pressure range: 1~150 psig, -50kPa, -100kPa.
-

■ Applications

- Industry control.
- Medical instrumentation.
- Pressure switch.
- Hospital bed.
- Pump control.

The MIS-3500 is an intelligent pressure sensor which consist of a MEMS piezoresistive pressure sensor and a CMOS sensor interface IC. The interface IC enables easy and precise calibration of resistive bridge sensors via EEPROM. It correct digitally offset、gain and both temperature coefficients. All devices were factory calibrated and temperature compensated. Using MIS-3500 series is easy to get rid of bothersome calibrations and temperature compensations. The MIS-3500 can provide 3V or 5V rail-to-rail ratiometric analog output.

■ Outline Dimensions

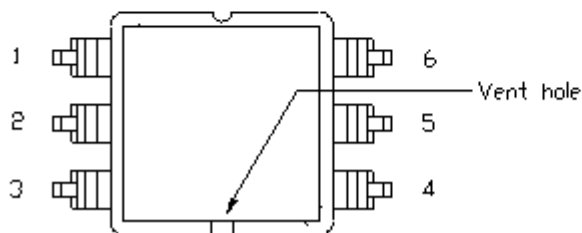
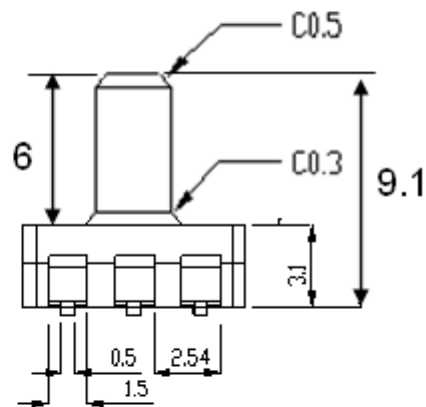
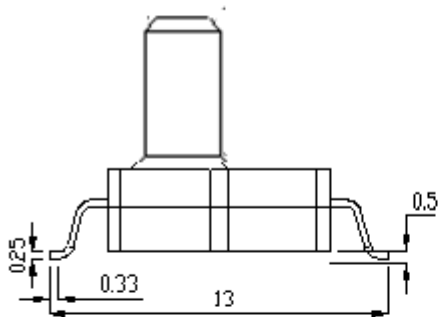
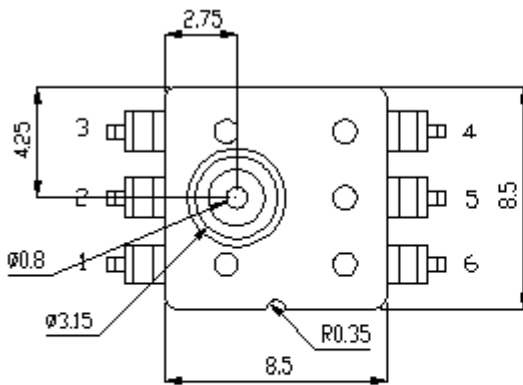

Unit: mm

■ Specifications

Parameter	Min	Typ	Max	Units	Notes
Absolute Maximum Ratings					
Supply Voltage	-0.3		6.0	V	
Maximum Overpressure			2X	Rated pressure	
Storage Temperature Range	-50		125	°C	
Operating Temperature Range	-40		85	°C	
Operating humidity	15		85	% RH	No condensation
Media Compatibility	Clean, dry air & non-corrosive gases				
Recommended Operating Conditions					
Pressure Range	1~150 psig · -500mbar · -1000mbar				
Supply Voltage					
MIS-3500 series	4.75	5	5.25	V	
MIS-3503 series	2.7	3	3.3		
Supply Current	0.25		2	mAdc	
Power ON Rise Time			100	ms	
Offset voltage (0 to 85°C)					
MIS-3500 series (Gauge:0psig, Vacuum:1atm)	0.16	0.25	0.34	V	rail to rail output
MIS-3503 series (Gauge:0psig, Vacuum:1atm)	0.096	0.15	0.204		
Full scale output (0 to 85°C)					
MIS-3500 series	4.66	4.75	4.84	V	rail to rail output
MIS-3503 series	2.796	2.85	2.904		
Full scale span (0 to 85°C)					
MIS-3500 series	4.32	4.5	4.68	V	rail to rail output
MIS-3503 series	2.592	2.7	2.808		
Accuracy					
20 to 60°C	-1.3		1.3	%FS	
0~20 & 60~85°C	-2		2		
Sensitivity					
1psi (5V/3V)		4.5 / 2.7	V/Psi		
5.8psi (5V/3V)		0.776 / 0.466	V/Psi		
15psi (5V/3V)		0.3 / 0.18	V/Psi		
30 psi (5V/3V)		0.15 / 0.09	V/Psi		
150 psi (5V/3V)		0.03 / 0.018	V/Psi		
-50kPa (5V)_D73V		0.09	V/kPa		
-100kPa (5V/3V) 015V		4.5E-2 / 2.7E-2	V/kPa		
Response time		1		ms	
Warm-up time		20		ms	
Offset stability			±0.25	%FS	
External Capacitance between Vdd and Gnd	100	220	470	nF	
Output load Capacitance		10	15	nF	
Notes :					
1. Unless otherwise specified, measurements were taken with a supply voltage of 5 Vdc at a temperature of 25±3°C and humidity ranging from 25% ~85% .					
Metrodyne Microsystem Corp. reserves the right to make changes to the product specification in this publication.					

■ Ordering Information

Part No.	Pressure type	Pressure range	Supply voltage	Note
MIS-3500-001G	Gauge	1 PSI	5V	
MIS-3500-006G	Gauge	5.8 PSI	5V	
MIS-3500-015G	Gauge	15 PSI	5V	
MIS-3500-030G	Gauge	30 PSI	5V	
MIS-3500-150G	Gauge	150 PSI	5V	
MIS-3500-015V	Vacuum	-1000mbar (-100kPa)	5V	Vacuum
MIS-3500-D73V	Vacuum	-500mbar (-50kPa)	5V	Vacuum
MIS-3503-001G	Gauge	1 PSI	3V	
MIS-3503-006G	Gauge	5.8 PSI	3V	
MIS-3503-015G	Gauge	15 PSI	3V	
MIS-3503-030G	Gauge	30 PSI	3V	
MIS-3503-150G	Gauge	150 PSI	3V	
MIS-3503-015V	Vacuum	-1000mbar	3V	Vacuum

■ Transfer Function

For MIS-3500 series :
$$P = \frac{(V_{out} - V_{off})}{4.5} \times P_{range}$$

For MIS-3503 series :
$$P = \frac{(V_{out} - V_{off})}{2.7} \times P_{range}$$

P : pressure value

V_{off} : Offset voltage, the output voltage of sensor without pressure applying.

V_{out} : The output voltage of sensor when pressure applied.

P_{range} : Pressure range of sensor.

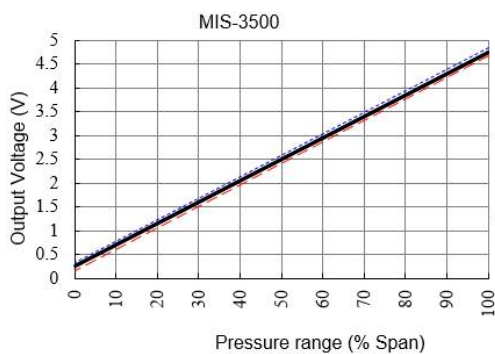

■ Pin Configuration

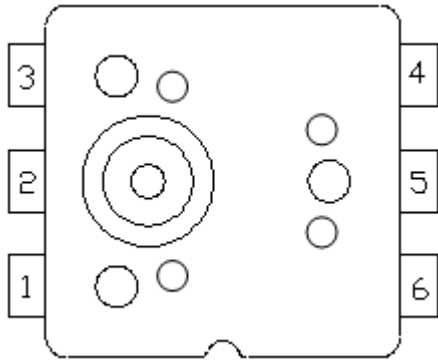

Pin No.	Name	Description
1	NC	No connection
2	NC	No connection
3	NC	No connection
4	VDD	Supply voltage
5	VOUT	Voltage output
6	GND	Ground supply

■ Application Circuit Examples

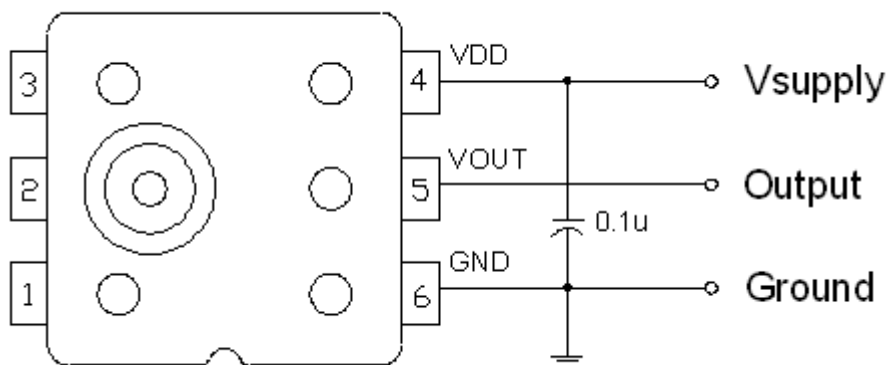

■ Recommended Footprint

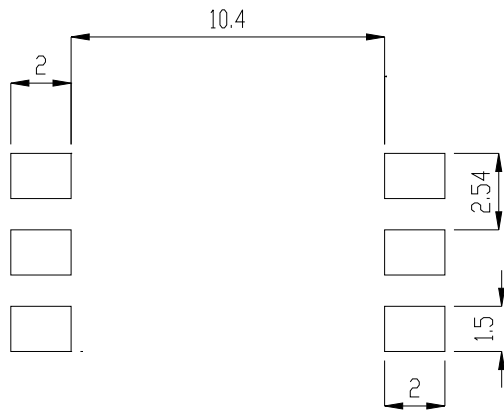

Unit: mm

 **Metrodyne Microsystem Corp.**

10, Prosperity Rd.II, Science-Based Industrial Park, Hsin-Chu 300, Taiwan, R.O.C.

Tel:886-3-5632161 Fax:886-3-5632509

E-mail:sales@metrodyne.com.tw <http://www.metrodynemems.com>