

## MIS-2500 series (Preliminary) Integrated Pressure Sensor

### ■ Features

- Factory calibrated and temperature compensated
- ±1.3%FS accuracy ( 20 to 60°C )
- 3V or 5V rail to rail ratiometric analog output
- Gauge pressure or vacuum type
- Pressure range: 1, 5.8, 15, 30, 150 psi & -1000mbar

### ■ Applications

- Industry control
- Medical instrumentation
- Pressure switch
- Hospital bed
- Pump control

The MIS-2500 is a intelligent pressure sensor which consist of a MEMS piezoresistive pressure sensor and a CMOS sensor interface IC. The interface IC enables easy and precise calibration of resistive bridge sensors via EEPROM. It correct digitally offset 、 gain and both temperature coefficients. All devices were factory calibrated and temperature compensated. Using MIS-2500 series is easy to get rid of bothersome calibrations and temperature compensations. The MIS-2500 can provide 3V or 5V rail-to-rail ratiometric analog output.

### ■ Specifications

Parameter	Min	Typ	Max	Units	Notes
<b>Absolute Maximum Ratings</b>					
Supply Voltage	-0.3		6.0	V	
Maximum Overpressure			2X	Rated pressure	
Storage Temperature Range	-40		125	°C	
Operating Temperature Range	-40		85	°C	
Operating humidity	0		95	% RH	No condensation
Media Compatibility	Clean, dry air & non-corrosive gases				
<b>Recommended Operating Conditions</b>					
Pressure Range	1 、 5.8 、 15 、 30 、 150 Psi & -1000mbar				
Supply Voltage					
MIS-2500 series	4.75	5	5.25	V	
MIS-2503 series	2.7	3	3.3		
Supply Current			2	mAdc	
Power ON Rise Time			100	ms	
Offset voltage ( 0 to 85°C )					
MIS-2500 series	0.16	0.25	0.34	V	rail to rail output
MIS-2503 series	0.096	0.15	0.204		
MIS-2507 series	0.11	0.2	0.29		
Full scale output ( 0 to 85°C )					
MIS-2500 series	4.66	4.75	4.84	V	rail to rail output
MIS-2503 series	2.796	2.85	2.904		
MIS-2507 series	4.61	4.7	4.79		
Full scale span ( 0 to 85°C )					
MIS-2500 、 MIS-2507 series	4.32	4.5	4.68	V	rail to rail output
MIS-2503 series	2.592	2.7	2.808		
Accuracy					
20 to 60°C	-1.3		1.3	%FS	
0 to 85°C	-2		2		
Response time		1		ms	

Warm-up time		20		ms	
Offset stability			±0.25	%FS	
External Capacitance between Vdd and Gnd	100	220	470	nF	
Output load Capacitance		10	15	nF	
Notes :					
1. Unless otherwise specified, measurements were taken with a supply voltage of 5 Vdc at a temperature of 25±3°C and humidity ranging from 25% ~ 85% .					
Metrodyne Microsystem Corp. reserves the right to make changes to the product specification in this publication.					

## ■ Ordering Information

Part No.	Pressure type	Pressure range	Supply voltage	Note
MIS-2500-001G	Gauge	1 PSI	5V	
MIS-2500-006G	Gauge	5.8 PSI	5V	
MIS-2500-006GR	Gauge	5.8 PSI	5V	Pressure port directed as leads
MIS-2500-015G	Gauge	15 PSI	5V	
MIS-2500-030G	Gauge	30 PSI	5V	
MIS-2500-150G	Gauge	150 PSI	5V	
MIS-2500-015V	Vacuum	-1000mbar	5V	Vacuum
MIS-2503-001G	Gauge	1 PSI	3V	
MIS-2503-006G	Gauge	5.8 PSI	3V	
MIS-2503-015G	Gauge	15 PSI	3V	
MIS-2503-030G	Gauge	30 PSI	3V	
MIS-2503-150G	Gauge	150 PSI	3V	
MIS-2503-015V	Vacuum	-1000mbar	3V	Vacuum
MIS-2507-150G	Gauge	150 PSI	5V	0.2 to 4.7V

## ■ Transfer Function

$$\text{For MIS-2500 series} \rightarrow P = \frac{(V_{out} - V_{off})}{4.5} \times P_{range}$$

$$\text{For MIS-2503 series} \rightarrow P = \frac{(V_{out} - V_{off})}{2.7} \times P_{range}$$

P : pressure value

V<sub>off</sub>: Offset voltage, the output voltage of sensor without pressure applying

V<sub>out</sub>: The output voltage of sensor when pressure applied

P<sub>range</sub> : Pressure range of sensor

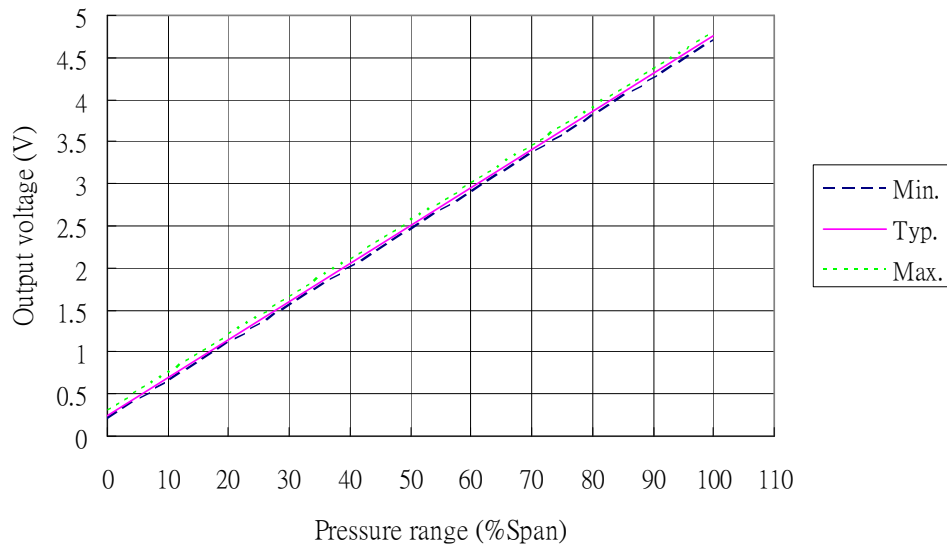
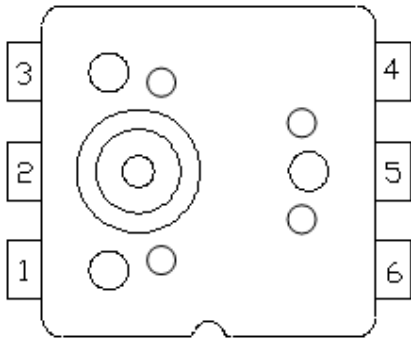

Fig.1 Output voltage vs. Pressure range

## ■ Pin Configuration



Pin No.	Name	Description
1	NC	No connection
2	NC	No connection
3	NC	No connection
4	VDD	Supply voltage
5	VOUT	Voltage output
6	GND	Ground supply

■ Application Circuit Examples

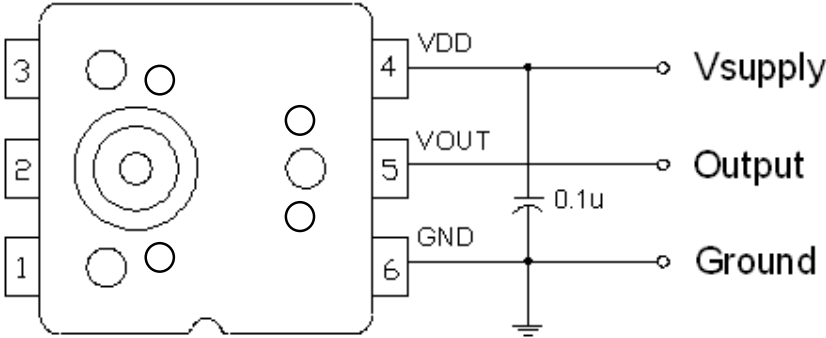

■ Recommended Footprint

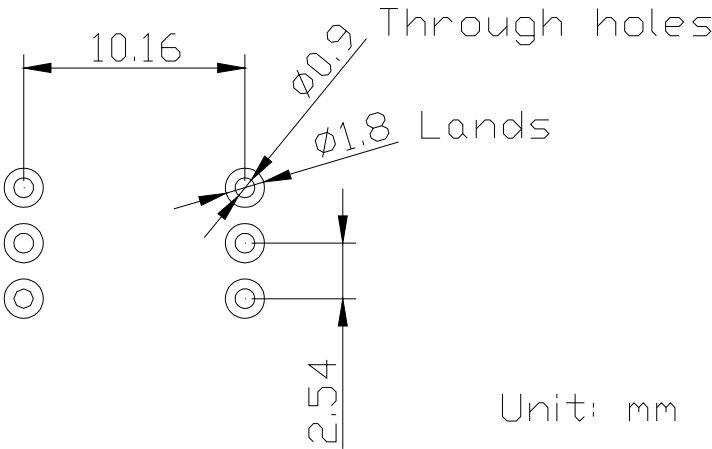

■ Outline Dimensions

➤ MIS-2500-006G

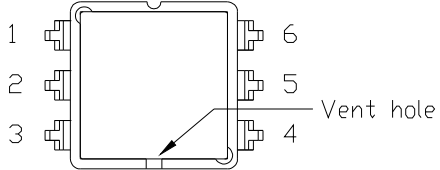
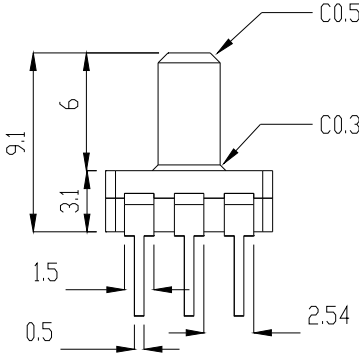
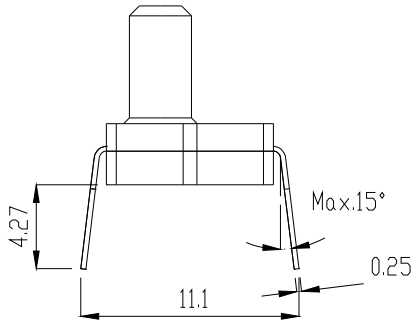
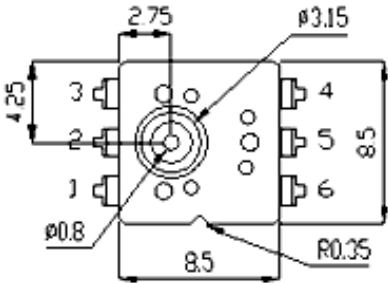

Unit: mm

➤ MIS-2500-006GR

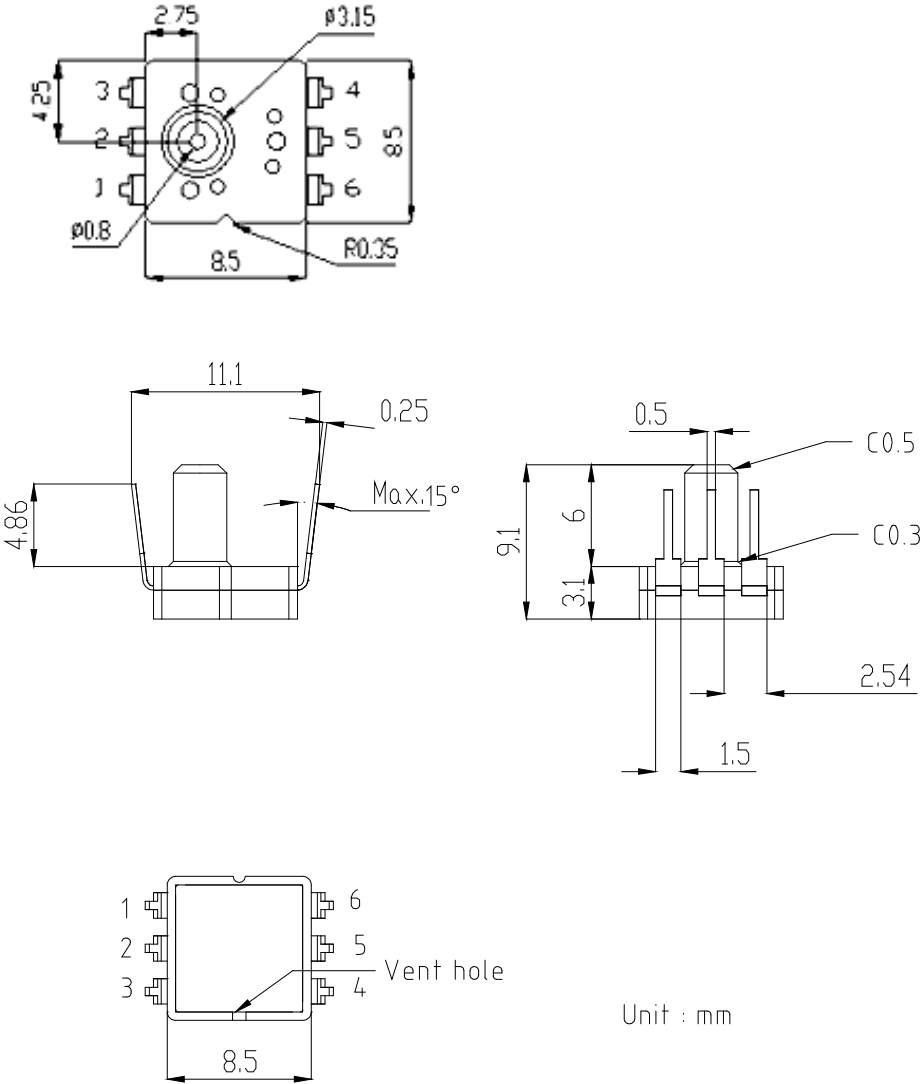

**Metrodyne Microsystem Corp.**  
 10, Prosperity Rd. II, Science-Based Industrial Park, Hsin-Chu 300, Taiwan, R.O.C.  
 Tel:886-3-5632161 Fax:886-3-5632509  
 E-mail:sales@metrodyne.com.tw <http://www.metrodyne.com.tw>